

HIGH PRESSURE WASHER PROFESSIONAL POWER EQUIPEMNT

OPERATION AND PARTS LIST MANUAL

SG/SH Series Belt Drive and Gearbox Reduction Gas Pressure Washer

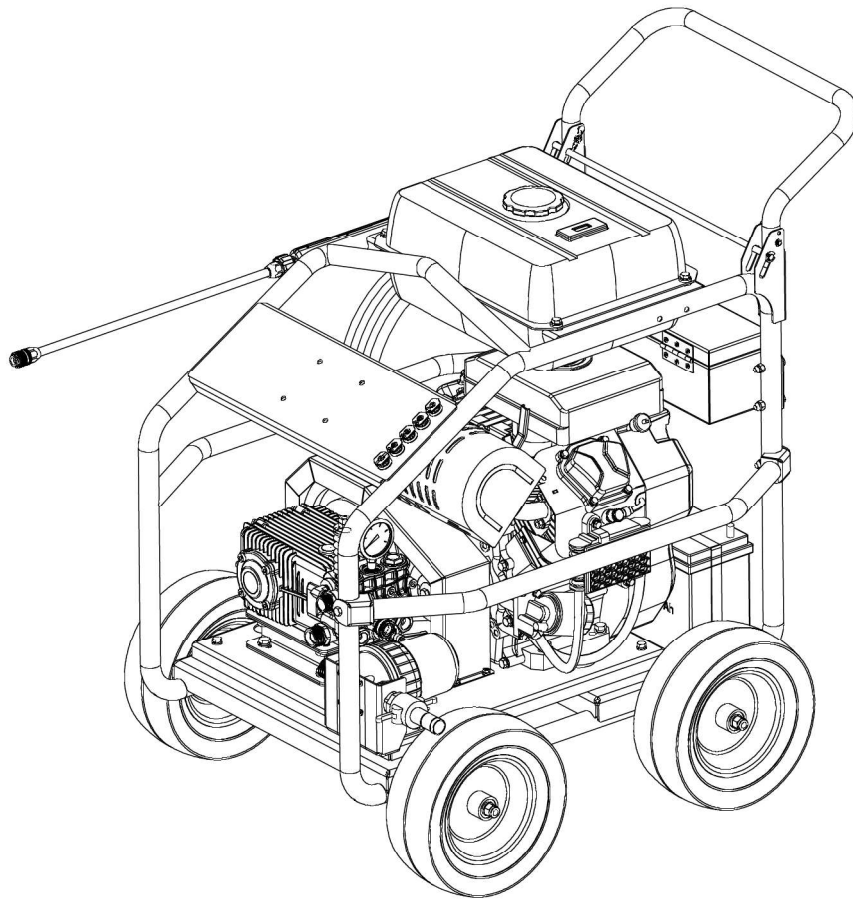

This manual contains:
IMPORTANT WARNINGS and **INSTRUCTIONS**. READ AND RETAIN FOR REFERENCE

⚠ WARNING: To reduce the risk of injury, the user must read and understand the operators manual before using this product.

SAVE THIS MANUAL FOR FUTURE REFERENCE

Contents

1. Introduction	1
2. Products Identification	2
3. Safety Guidelines	2,3,4,5
4. Products Specifications	6
5. Parts Identification and Features	7,8
6. Machine Overall Size	9
7. Setting Up the Before Use	10,11
8. Safe Working Environment	12
9. Startup and Stop Procedure	13
10. Adjusting Pump Pressure	14
11. Using Nozzles	14
12. Maintenance	15,16
13. Storage	17
14. Troubleshooting	18,19
15. Pressure Washer Exploded View & Parts List	20
16. Pump Exploded View & Parts List	21
17. Gearbox Exploded View & Parts List	22

Disclaimer:

The information in this document is to the best of our knowledge true and accurate, but all recommendations or suggestions are made without guarantee. Since the conditions of use are beyond their control, the factory disclaim any liability for loss or damage suffered from the use of this data or suggestions. Furthermore, no liability is accepted if use of any product in accordance with this data or suggestions infringes any patent. The factory reserve the right to change product specifications and warranty statements without further notification. All images are for illustration purposes only.

1. Introduction

Thank you for purchasing this **Professional Power Equipment Product**.

Please read the following instructions carefully to help to ensure your personal safety and the correct assembly, use and maintenance of this equipment. Please ensure that you have read and understand the information contained in the manual before attempting to use the equipment. This equipment should only be used by trained and fully competent individuals, in a safe working environment. Please ensure that the appropriate safety equipment is worn at all times and that the product is not adapted or modified in anyway.

Please note that the contents of this instruction manual are based on the latest product information available at the time of publication and that the manufacturer reserves the right to make changes at any time without notice.

2. Products Identification

RECORD IDENTIFICATION NUMBERS

If you need to contact an Authorized Dealer for information on servicing, always provide the product model and identification numbers. You will need to locate the model, revision and serial number for the machine and record the information in the places provided below. You will also need the model and serial number for the engine on your machine.

1. Date of Purchase: _____
2. Dealer Name: _____
3. Dealer Phone: _____
4. Unit Model Name: _____
6. Pump Model & Serial Number: _____
5. Engine Model & Serial Number: _____

NOTE: Check **Page 8** for the location of the pump model & serial no. on the pump. Check the engine operators manual for the location of these numbers.

3. Safety Guidelines



WARNING- READ AND FOLLOW ALL INSTRUCTIONS

- Failure to follow all instructions in this manual may result in severe personal injury or death. Keep this manual and refer to it for Safety Instructions, Operating Procedures, and Warranty.



This manual contains information that is important for you to know and understand. This information relates to protecting **YOUR SAFETY** and **PREVENTING EQUIPMENT PROBLEMS**. To help you recognize this information, we use the symbols below. Please read the manual and pay attention to these sections.



DANGER

DANGER indicates an imminently hazardous situation which, if not avoided, will result in death or serious injury.



CAUTION

CAUTION indicates a potentially hazardous situation which, if not avoided, may result in minor or moderate injury.



WARNING

WARNING indicates a potentially hazardous situation which, if not avoided, could result in death or serious injury.



CAUTION

CAUTION used without the safety alert symbol indicates a potentially hazardous situation which, if not avoided, may result in property damage.

Improper maintenance and operation are responsible for the majority of accidents involving gas pressure washers. The largest portion of these could be prevented by recognizing the basic safety rules and precautions. Most accidents can be avoided if the operator recognizes a potentially hazardous situation before it happens and by observing appropriate safety rules and procedures as outlined in this manual. Basic safety precautions are outlined in the **SAFETY** portion of this manual and throughout the text in this manual where a potential hazard might occur. Hazards that **MUST** be avoided to prevent serious injury follow headers marked **DANGER** or **WARNING**. These same precautions are placed as labels on the tool itself. **NEVER** use this pressure washer for applications that are **NOT** specified in this manual.

3. Safety Guidelines (continued)



DANGER-- RISK TO BREATHING

- **Running engine gives off carbon monoxide, an odorless, colorless, poison gas.**
- **Breathing carbon monoxide can cause nausea, fainting or death.**
- **Some chemicals or detergents may be harmful if inhaled or ingested, causing severe nausea, fainting or poisoning.**



- **ALWAYS** Operate pressure washer in a well ventilated area. Avoid enclosed areas such as garages, basements, etc.
- **ALWAYS** Keep exhaust gas from entering a confined area through windows, doors, ventilation intakes, or other openings.
- **ALWAYS** follow manufacturers recommendations, use a respirator or mask whenever there is a chance that vapors may be inhaled.
- **ALWAYS** use the only fluids specifically recommended for high pressure washers.
- **NEVER** operate unit in a location occupied by humans or animals.
- **NEVER** use chlorine bleach or any other corrosive compound.



DANGER--RISK OF EXPLOSION OR FIRE

- **Fuel and its vapors are extremely flammable and explosive.**
- **Fire or explosion can cause severe burns or death.**



ALWAYS shut off engine and allow it to cool a least 2minutes before adding fuel to the tank.

ALWAYS use care in filling tank to avoid spilling fuel. Move pressure washer away from fueling area before starting engine.

ALWAYS Keep maximum fuel level below top of tank to allow for expansion.

ALWAYS operate and fuel equipment in well ventilated areas free from obstructions. Equip areas with fire extinguishers suitable for gasoline fires.

ALWAYS keep pressure washer a minimum of four feet away from surfaces (such as houses, automobiles, or live plants) that could be damaged from muffler exhaust heat.

ALWAYS Store fuel in an OSHA approved container, in a secure location away from work area.

NEVER spray flammable liquids

NEVER operate pressure washer in an area containing dry brush or weeds.



WARNING--RISK OF FALL HAZARD

- **Use of pressure washer can create puddles and slippery surfaces.**
- **Kickback from spray gun can cause you to fall.**



- Keep the area of operation clear of all persons, particularly small children, pets and obstacles.
- Do not operate the product when fatigued or under the influence of alcohol or drugs. Stay alert at all times.
- If engine does not start after two pulls, squeeze trigger of gun to relieve pump pressure. Pull starter cord slowly until resistance is felt. Then pull cord rapidly to avoid kickback and prevent hand or arm injury.
- Do not overreach or stand on an unstable support.
- The cleaning area should have adequate slopes and drainage to reduce the possibility of a fall due to slippery surfaces.
- Be extremely careful if you must use the pressure washer from a ladder, scaffolding, or any other similar location.
- Beware of kick-back force and the sudden torque on the spray gun assembly when operating the trigger. Firmly grasp spray gun with both hands to avoid injury when spray gun kicks back.

3. Safety Guidelines (continued)



WARNING--RISK TO FLUID INJECTION

- The high pressure stream of water that this equipment produces can cut through skin and its underlying tissues, leading to serious injury and possible amputation. Spray gun traps high water pressure, even when engine is stopped and water is disconnected, which can cause injury.

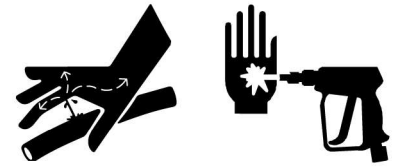

- **ALWAYS** point spray gun in safe direction and squeeze trigger, to release high pressure, every time you stop engine.
- **NEVER** place hands in front of nozzle.
- **MAKE SURE** hose and fittings are tightened and in good condition. Never hold onto the hose or fittings during operation.
- **DO NOT** allow hose to contact muffler.
- **NEVER** attach or remove wand or hose fittings while system is pressurized.
- **NEVER** use a spray gun which does not have a trigger lock or trigger guard in place and in working order.
- **ONLY USE** hose and high pressure accessories rated for pressure higher than your pressure washer's p.s.i.
To relieve system pressure, shut off engine, turn off water supply, and pull gun trigger until water stops flowing.
- **DO NOT** allow **CHILDREN** to operate pressure washer.
- **NEVER** repair leaking connections with sealant of any kind. Replace o-ring or seal.
- **NEVER** connect high pressure hose to nozzle extension.
- **DO NOT** secure spray gun in open position.
- **DO NOT** leave spray gun unattended while machine is running.
- **ALWAYS** be certain spray gun, nozzles and accessories are correctly attached.
- **NEVER** aim spray gun at people, animals, or any electrical device and the machine itself.

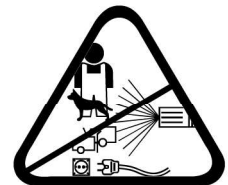

DANGER-- RISK OF CHEMICAL BURN

- Use of acids, toxic or corrosive chemicals, poisons, insecticides, or any kind of flammable solvent with this product could result in serious injury or death.



- **DO NOT** use acids, gasoline, kerosene, or any other flammable materials in this product. Use only household detergents, cleaners and degreasers recommended for use in pressure washers.
- Wear protective clothing to protect eyes and skin from contact with sprayed materials.
- **DO NOT** use chlorine bleach or any other corrosive compound



WARNING--RISK OF ELECTRICAL SHOCK

- Risk of electrocution.
- Contact with power source can cause electric shock or burn.



- Unplug any electrically operated product before attempting to clean it.
- Direct spray away from electric outlets and switches.
- **NEVER** spray near power source.
- **DO NOT** touch the plug with wet hands.
- **WHEN SERVICING THE PRESSURE WASHER:** Disconnect the spark plug wire and place it where it cannot contact the plug. **DO NOT** check for spark with the plug removed. Use only approved spark plug testers.

3. Safety Guidelines (continued)



DANGER-- RISK OF HOT SURFACES

- Contact with hot surfaces, such as engines exhaust components, could result in serious burn.



- During operation, touch only the control surfaces of the pressure washer.
- Keep children away from the pressure washer at all times. They may not be able to recognize the hazards of this product.
- **DO NOT** let hoses come in contact with very hot engine muffler during or immediately after use of your pressure washer.
- **AVOID** hot exhaust gases.



DANGER-- RISK OF MOVING PARTS

- Starter and other rotating parts can entangle hands, hair, clothing, or accessories.



- **NEVER** operate pressure washer without protective housing or covers.
- **DO NOT** wear loose clothing, jewelry or anything that may be caught in the starter or other rotating parts.
- Tie up long hair and remove jewelry.



DANGER-- RISK OF EYE INJURY

- Spray can splash back or propel objects.

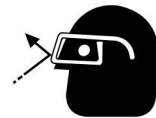

- **ALWAYS** wear safety goggles when using this equipment or in vicinity of where equipment is in use.
- Before starting the pressure washer, be sure you are wearing adequate safety goggles.
- **NEVER** substitute safety glasses for safety goggles.



CAUTION– IMPROPER TREATMENT OF PRESSURE WASHER CAN DAMAGE IT AND SHORTEN ITS LIFE AND VOID YOUR WARRANTY

- **NEVER** pull water supply hose to move pressure washer. This could damage hose and/or pump inlet.
- **DO NOT** use hot water, use cold water only.
- **NEVER** turn water supply off while pressure washer engine is running or damage to pump will result.
- **DO NOT** stop spraying water for more than two minutes at a time. Pump operates in bypass mode when spray gun trigger is not pressed. If pump is left in bypass mode for more than two minutes internal components of the pump can be damaged.
- Before starting pressure washer in cold weather, check all parts of the equipment to be sure ice has not formed there.
- **DO NOT** use the pressure washer if excessive noise or vibration is present. Have it repaired immediately.

PLEASE WEAR PROPER APPAREL AND PROTECTORS



Proper Apparel



Electrically
Non-conductive Gloves















Ear Protection



Nonskid Footwear

4. Products Specifications

Model	DCF-33/25GRSH	DCF-33/25GBSH	DCF-47/17GRSH	DCF-47/17GBSH
Max Pressure 	4800psi/330bar	4800psi/330bar	6900psi/476bar	6900psi/476bar
Max Flow 	6.6gpm/25lpm	4.5gpm/17lpm	4.6gpm/17.4lpm	4.6gpm/17.4lpm
Pump Model 	DBF-1821G2, Gearbox	DBF-1821B, Belt drive	DBF-1521G2, Gearbox	DBF-1521B, Belt drive
Power And Type 	22hp/620cc, OHV	22hp/620cc, OHV	22hp/620cc, OHV	22hp/620cc, OHV
Start Type 	Electric start	Electric start	Electric start	Electric start
Battery 	Battery 12V/36Ah	Battery 12V/36Ah	Battery 12V/36Ah	Battery 12V/36Ah
Gun And Lance 	Stainless steel trigger gun	Stainless steel trigger gun	Stainless steel trigger gun	Stainless steel trigger gun
High Pressure Hose 	Hydraulic high pressure hose	Hydraulic high pressure hose	Hydraulic high pressure hose	Hydraulic high pressure hose
Nozzle 	Standard thread nozzle at 25°	Standard thread nozzle at 25°	Standard thread nozzle at 25°	Standard thread nozzle at 25°
Wheel 	4 x 13" Pneumatic wheel	4 x 13" Pneumatic wheel	4 x 13" Pneumatic wheel	4 x 13" Pneumatic wheel
Shipping Size 	95x80x94cm	95x80x85cm	95x80x94cm	95x80x94cm
Shipping Weight 	145kgs	145kgs	145kgs	145kgs

5. Parts Identification and Features

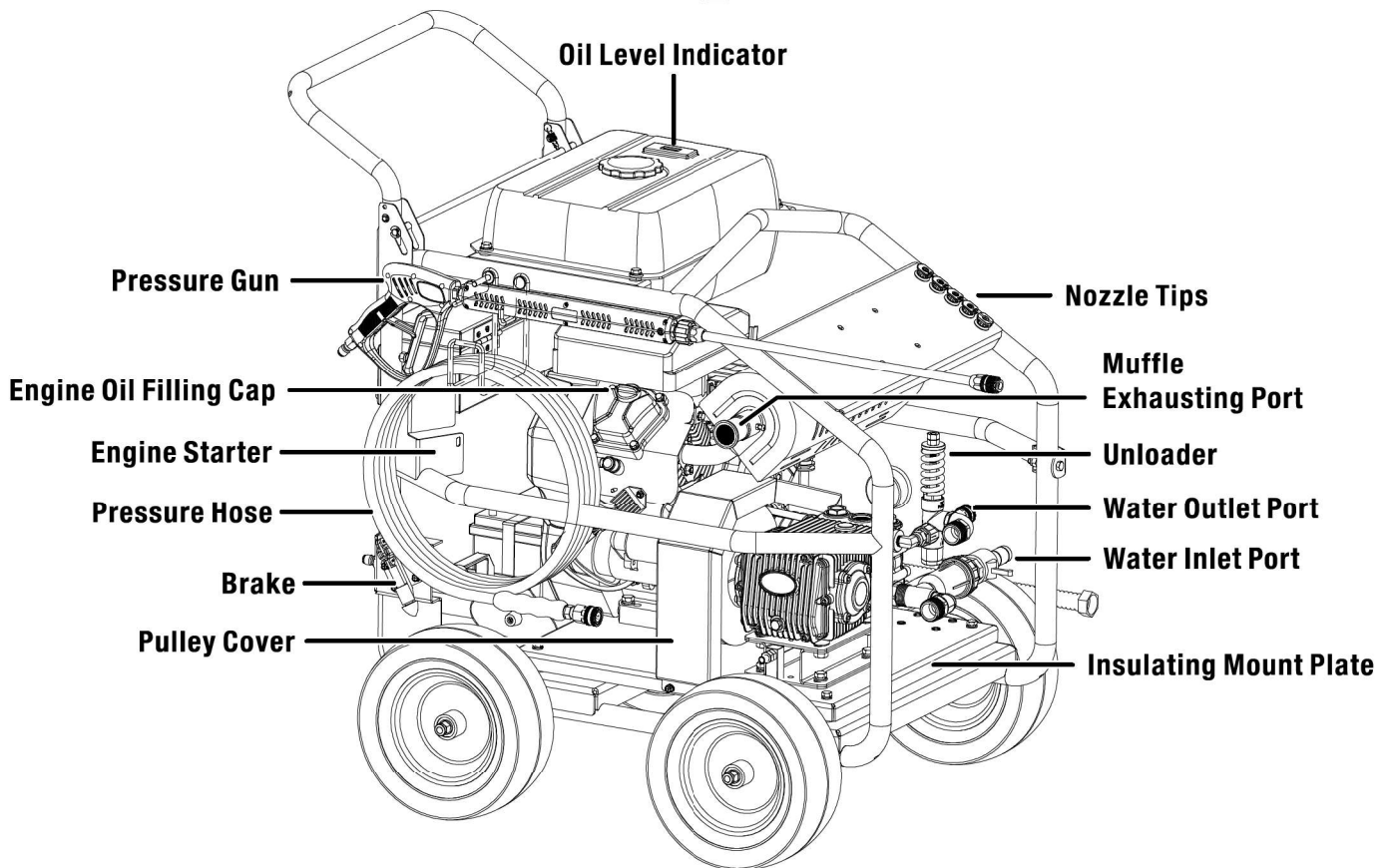
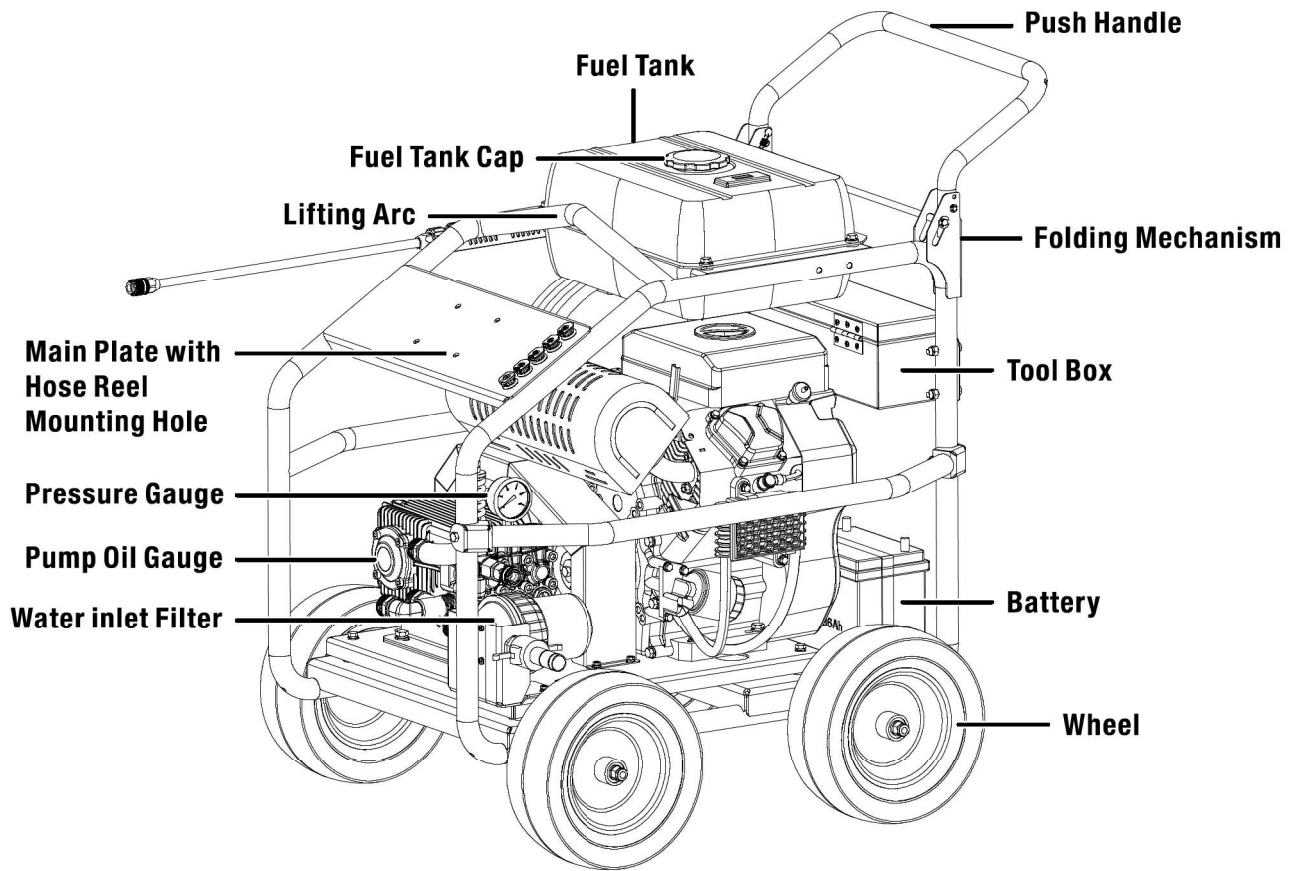

5. Parts Identification and Features (continued)

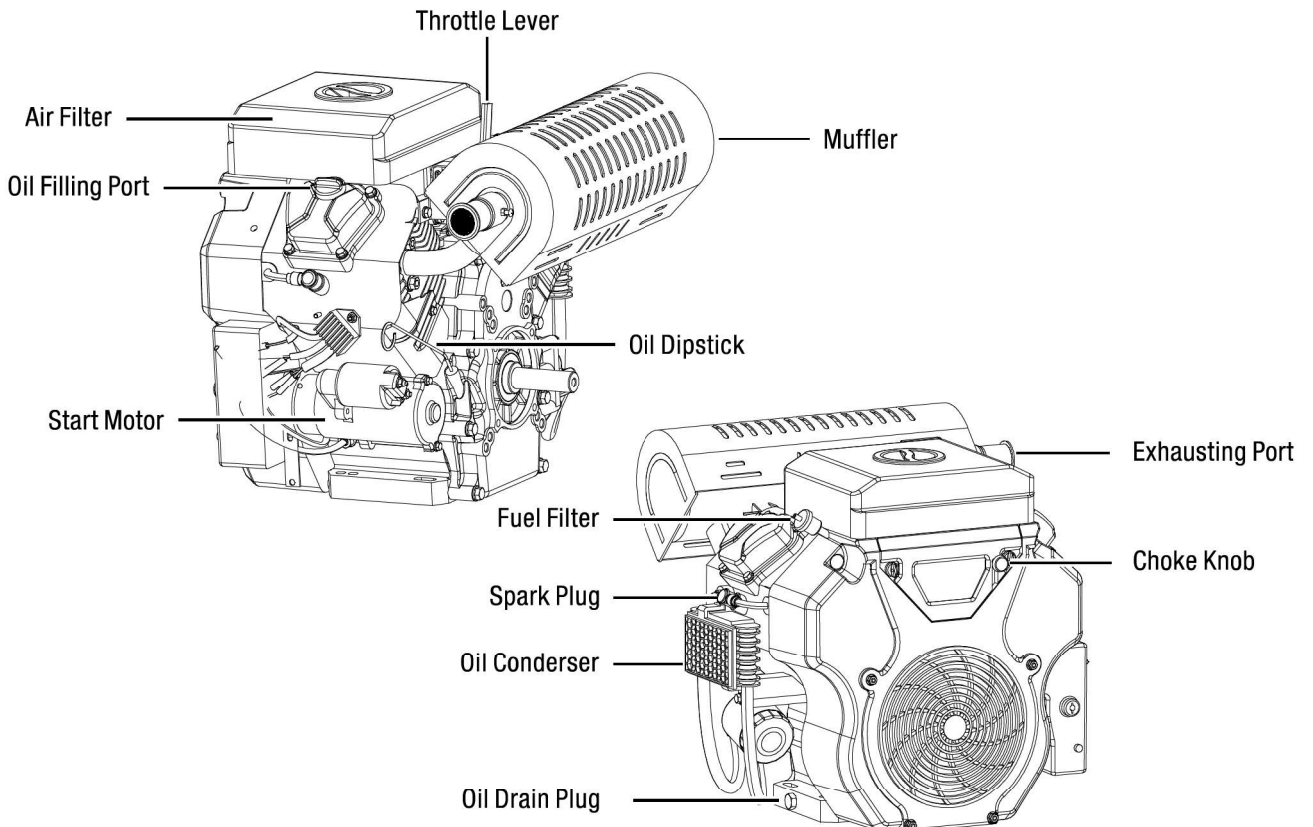
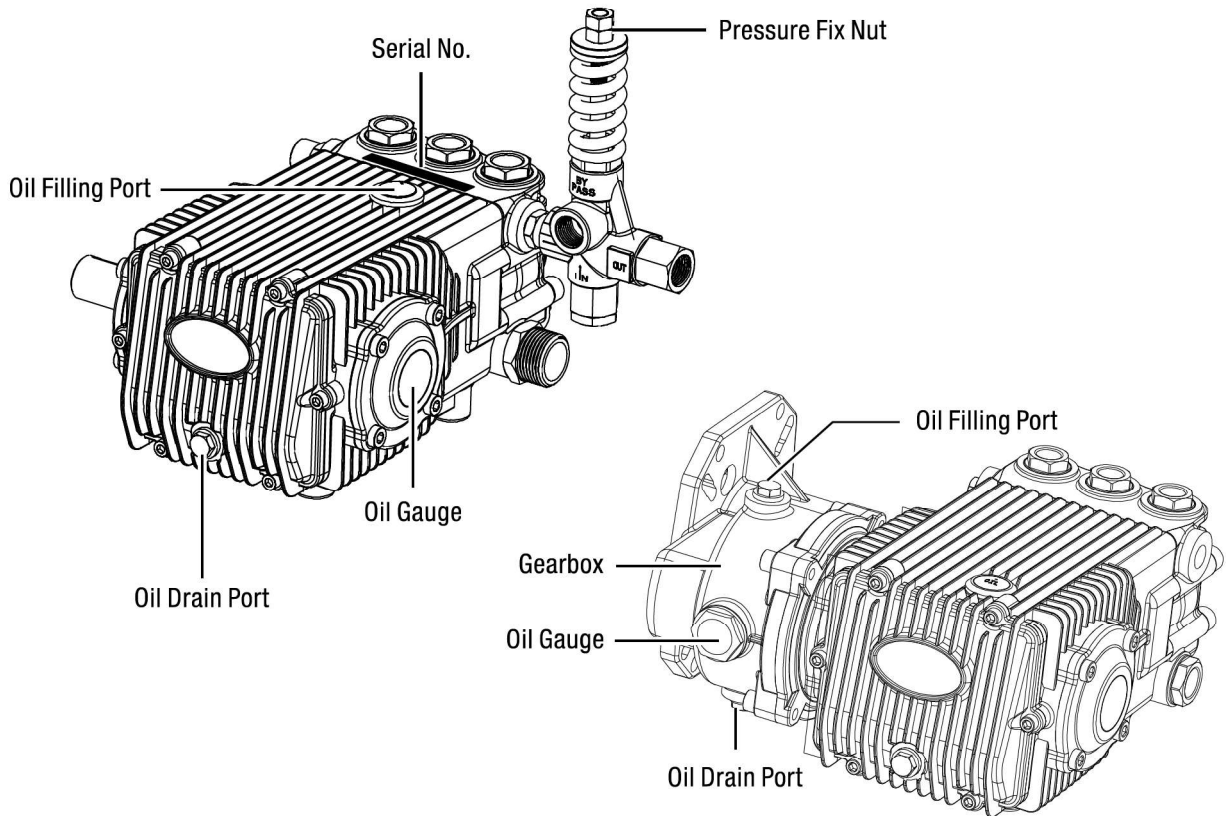

6. Machine Overall Size

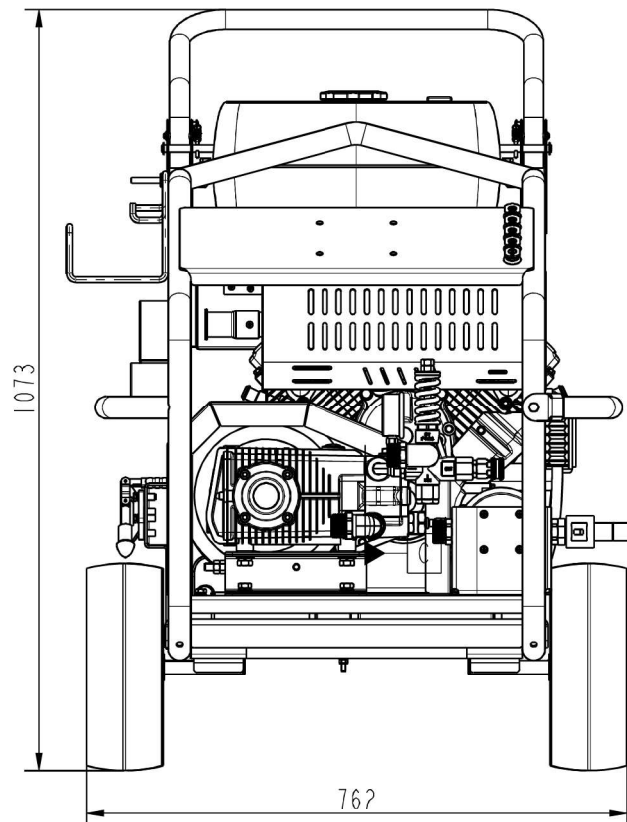
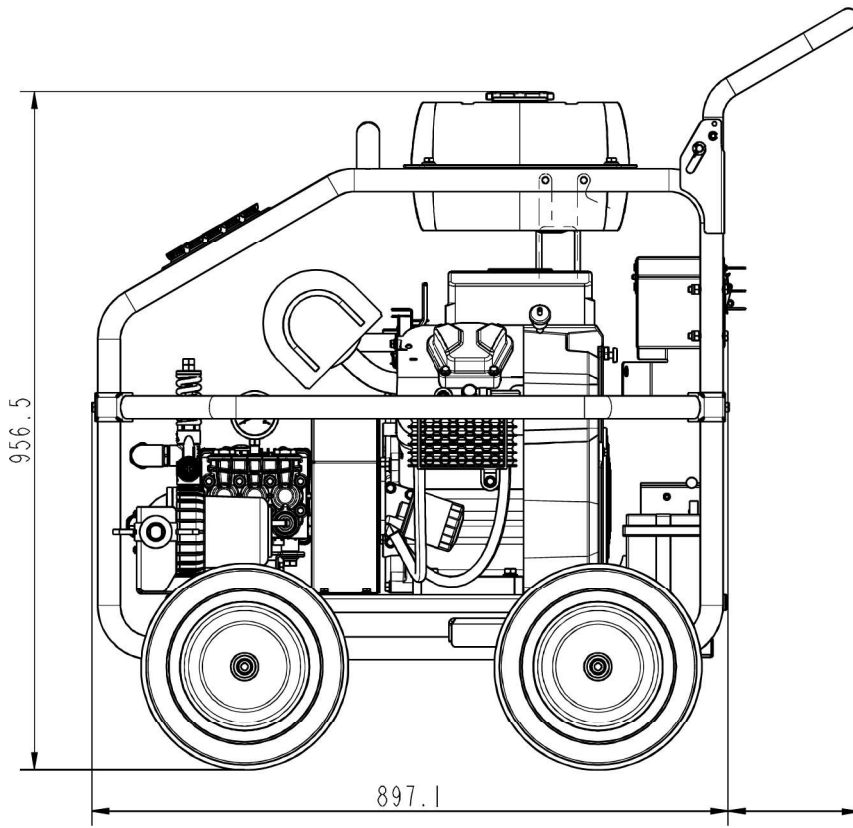

7. Setting Up Before Use

1. Preparing Pressure Pump and Gearbox



WARNING

Operating the pump with no or low oil will cause permanent damage, check oil level before first start, and every time before use.

- 1.1 Check the oil glass on the end of pressure pump and gearbox to ensure oil is at 1/2 of the sight glass level
- 1.2 Add oil if level is below indicator on oil gauge. Use 30-weight non-detergent oil both for the pump and gearbox..
- 1.3 Outdoor temperatures determine the proper oil viscosity.
 - **Below 40 F (4 C) the use of SAE 30 will result in hard starting.
 - **Above 80 F (27 C) the use of 10W30 may cause increased oil consumption. Check oil level more frequently.

2. Connect the Water Supply to Unit

- 2.1 Push the water inlet hose (ID25mm) onto the hose barb and lock the hose with the hose hoop.
- 3.2 The water inlet feature a quick connect hook construct for easy installation.

3. Connect the High Pressure Hose to the Outlet

Push back the collar on the outlet quick connector, insert the plug of the high pressure hose into the socket, release the collar and pull back the hose to make sure it is firmly locked.

4. Connect Battery Cable

Connect the Positive (+) Cable onto the Start Solenoid Terminal as shown, and connect the Negative (-) Cable to an engine mounting bolt like frame bolt, or other good engine ground connection.



WARNING

- A battery can explode if you do not follow the correct procedure,
- seriously injuring anyone nearby. Keep all sparks, open flames, and smoking materials away from the battery.

5. Attaching High Pressure Hose to Spray Gun

Push back the collar on the high pressure hose, insert the plug of the high pressure gun into the socket, release the collar and pull back the hose to make sure it is firmly locked.

6. Connecting Spray Wand to Spray Gun

Thread spray wand onto spray gun.

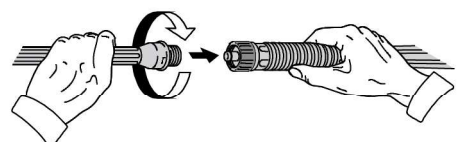
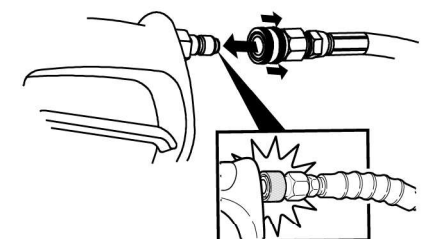
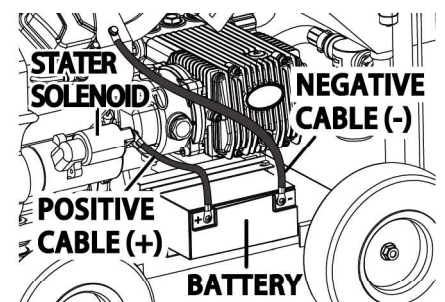
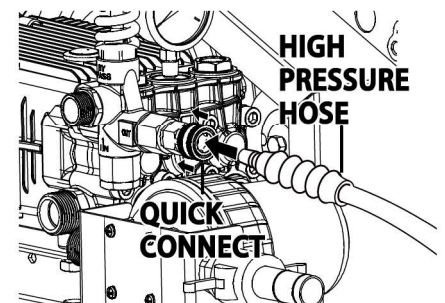
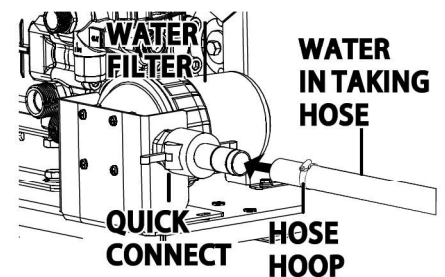
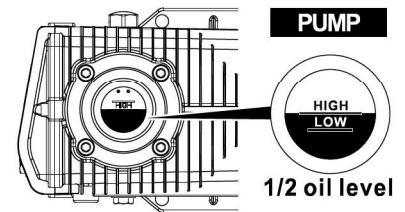
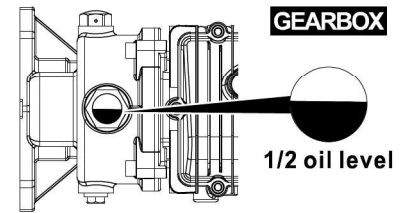

7. Setting Up Before Use (Continued)

7. Add Oil To The Engine

1. Place pressure washer on a flat, level surface.
2. Clean area around oil fill and remove yellow oil fill cap.
3. Using oil funnel (optional), slowly pour contents of provided oil bottle into oil fill opening.
4. Replace oil fill cap and fully tighten.



NOTICE

Improper treatment of pressure washer can damage it and shorten its life.

DO NOT attempt to crank or start the engine before it has been properly serviced with the recommended oil. This may result in an engine failure.

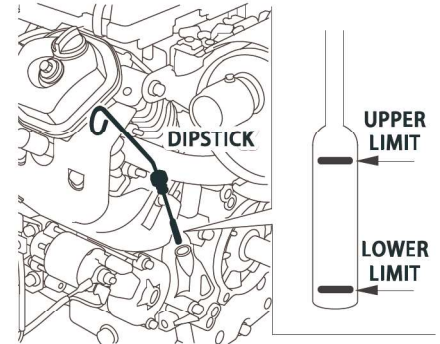

8. Add Fuel To the Engine



WARNING

Failure to use fuel as recommended in this manual will void the warranty.

DO NOT use unapproved gasoline such as E85 (85% ethanol/15% gasoline).

DO NOT mix oil with gasoline.

DO NOT modify engine to run on alternate fuels.

Mix in a fuel stabilizer when adding fuel to pressure washer to protect fuel system from forming gum deposits. If engine doesn't run properly after fueling, switch fuel brands. The engine is certified to run on gasoline. The emission control system for this engine is EM (Engine Modifications).

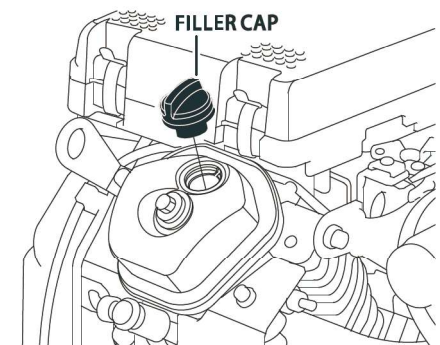

WARNING

Fuel and fuel vapor are extremely flammable and explosive. Fire or explosion from misuse of fuel can cause severe burns and even death.

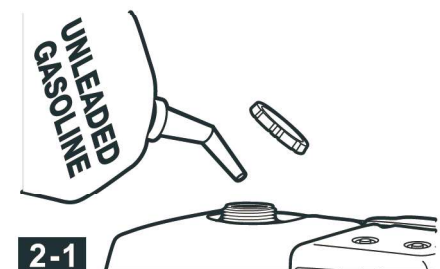

WHEN ADDING FUEL TO PRESSURE WASHER, OBSERVE THE FOLLOWING STEPS:

1. Turn pressure washer **OFF** and let it cool for at least two minutes before removing fuel cap. Loosen fuel cap slowly to release pressure.
2. Fill fuel tank outdoors.
3. **DO NOT** overfill fuel tank. Leave room for fuel to expand.
4. Wait for spilled fuel to evaporate before cranking engine.
5. Keep fuel away from sparks, open flames, pilot lights, heat and other ignition sources.
6. **DO NOT** light a cigarette or smoke near open fuel tank or container.
7. Clean area around fuel fill cap and slowly remove cap to allow any pressure to escape.
8. Slowly add unleaded gasoline **(A)** to fuel tank **(B)**. Use extreme caution not to fill fuel above baffle **(C)**. This allow appropriate space for fuel expansion.
9. Install fuel cap and allow any spilled fuel to evaporate before starting engine.

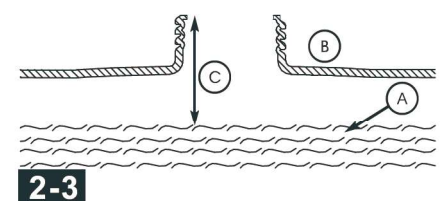
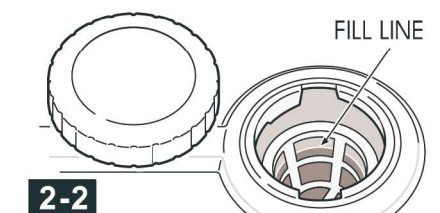

8. Safe Working Environment

Pressure Washer Location

Clearances and Air Movement



WARNING

- Exhaust heat/gases can ignite combustibles, structures or damage fuel tank causing a fire.

Keep at least 5 ft. (1.5 m) clearance on all sides of pressure washer including overhead.



Place pressure washer in a well ventilated area, which will allow for removal of deadly exhaust gas. Do not place pressure washer where exhaust gas could accumulate and enter inside or be drawn into a potentially occupied building. Ensure exhaust gas (A) is kept away from any windows, doors, ventilation intakes, or other openings that can allow exhaust gas to collect in a confined area. Prevailing winds and air currents should be taken in



WARNING

- Running engine gives off carbon monoxide, an odorless, colorless, poison gas.
- Breathing carbon monoxide can cause headache, fatigue, dizziness, vomiting, confusion, seizures, nausea, fainting or death.

Operate pressure washer ONLY outdoors.

Keep exhaust gas from entering a confined area through windows, doors, ventilation intakes, or other openings.

DO NOT start or run engine indoors or in an enclosed area, even if windows and doors are open.

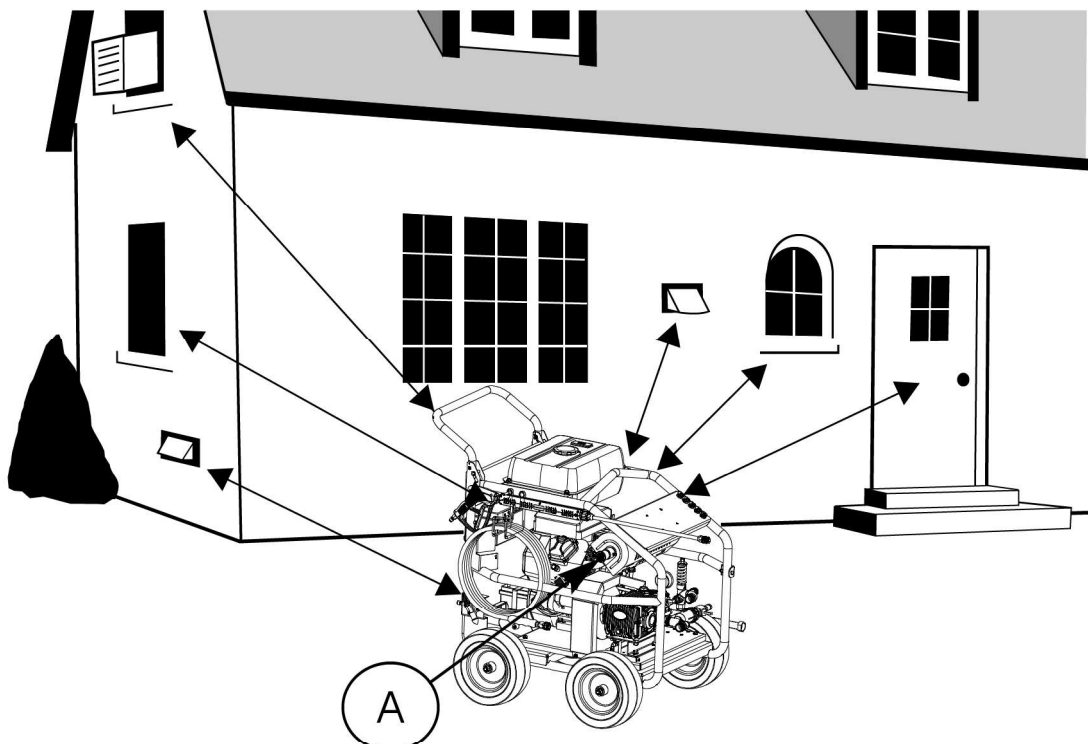

9. Start Up and Stop Procedure

1. How to Start Your Pressure Washer

To start your pressure washer for the first time, follow these instructions step-by-step. This starting information also applies if you have let the pressure washer sit idle for at least a day.

- 1.1 Place pressure washer near an outside water source capable of supplying water at a flow rate at least 5 gallons per minute and no less than 20 PSI at pressure washer end of garden hose.
- 1.2 Check that high pressure hose is tightly connected to spray gun and pump.
- 1.3 Make sure unit is in a level position.
- 1.4 Uncoil high pressure hose completely before using pressure washer.
- 1.5 Connect garden hose to water inlet on pressure washer pump.
- 1.6 Turn ON water, point gun in a safe direction and squeeze trigger to purge pump system of air and impurities.



NOTICE

- **DO NOT** run the pump without the water supply connected and turned on.
- **Damage to equipment resulting from failure to follow this instruction will void warranty.**

- 1.7 Attach wand to spray gun. Tighten by hand.
- 1.8 Choose the nozzle you want to use, pull back on collar of quick connector, insert nozzle and release collar. Tug on nozzle to make sure it is securely in place.
- 1.9 Rotate fuel shut-off valve to "On" position.
- 1.10 To start a **cold engine**, pull the "Choke Knob" out to the **CLOSED** position.

NOTE: For a **warm engine**, be sure the choke lever is in the "OPEN" position.

- 1.11 Move the throttle lever away from the "MIN" position about 1/3 of the way toward the "MAX" position.

IMPORTANT: Before starting the pressure washer, be sure you are wearing adequate safety goggles.

- 1.12 Turn the engine switch to the "ON" position, and turn the key to "START" position and hold it there until the engine starts. If the engine fail to start within 5 seconds, release the key and wait at least 10 seconds before operating the starter again.

NOTE: Using the electric starter for more than 5 seconds at a time will overheat the starter motor and can damage it.

- 1.13 When engine starts, if the **Choke Knob** has been pulled to the "CLOSED" position, gradually push it to the "OPEN" position as the engine warms.
- 1.14 Position the **Throttle Lever** for the desired engine speed.

IMPORTANT: Allow the Engine to run at no load, low pressure for five minutes after each start-up so Engine can stabilize.

2. How to Stop Your Pressure Washer

- 2.1. Release spray gun trigger and let engine idle for two minutes.
- 2.2. Move throttle control lever on engine to "MIN" position.
- 2.3. **ALWAYS** point spray gun in a safe direction, turn the Engine Switch to and "OFF" position, and squeeze spray gun trigger to release retained high water pressure.

IMPORTANT: Spray gun traps high water pressure, even when engine is stopped and water is disconnected. Pull the trigger to release the pressure.

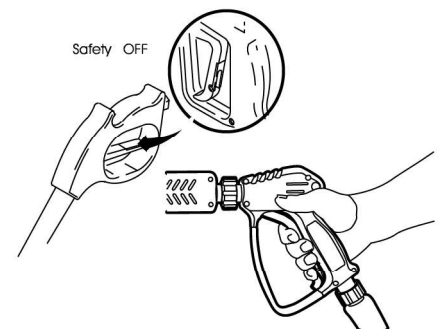
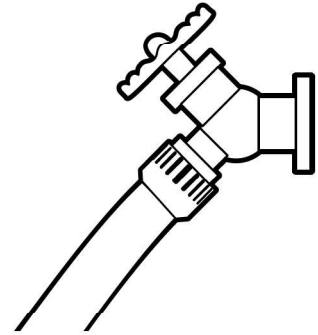

CHOKE KNOB

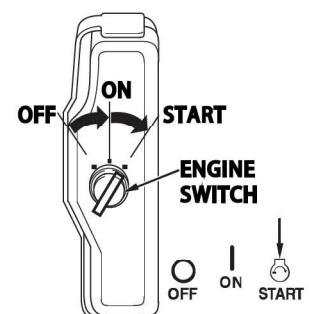
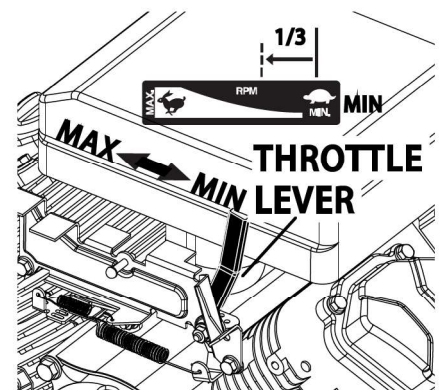
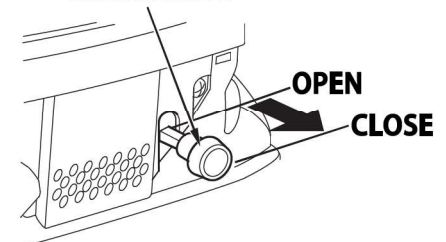

10. Adjusting Pump Pressure

1. Pressure Rinsing

1. Use a 16mm open end spanner to turn the top nut “**Anticlockwise**” to loose the nut.
2. Use the same spanner to tun the bottom nut “**Clockwise**” to push the unloader spring down and to rinsing the pump pressure.
3. Hold the bottom nut with one spanner and tighten the top nut to fix the two nut in place to hold the pressure rate.

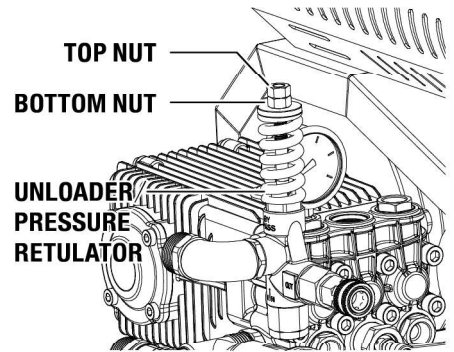

11. Using Nozzles

1. Attaching Pressure Nozzles to Spray Wand

1. Engage trigger lock on spray gun.
2. Pull slip ring on female quick-disconnect fitting of spray wand back.
3. Insert nozzle into female quick-disconnect socket on spray wand.
4. Release slip ring on female quick-disconnect and twist. Listen for “lick” to ensure both quick-disconnects are coupled.
5. Pull high pressure nozzle and spray wand in opposite direction to ensure they do not separate.

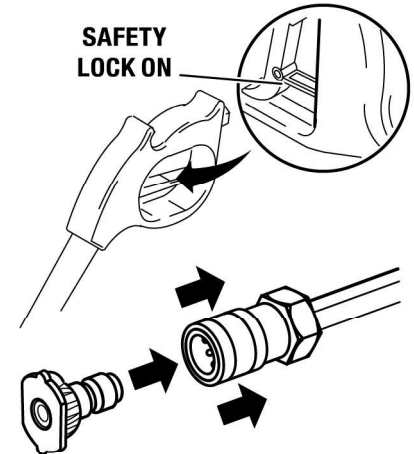

2. Nozzle Size Guide

The pressure washer comes with five spray nozzles. Each nozzle is color coded and delivers a specific spray pattern and pressure for a particular cleaning job. The size of the nozzle determines the size of the fan spray and the pressure out of the nozzle. They are stored in receptacles on a panel mounted to the handle of the washer. Colors on the panel identify nozzle location and spray panel.

WARNING

- Pressure washer produces fluid pressures and velocities high enough to penetrate human and animal flesh which could result in serious injury or amputation.
- Do not point pressure washer in direction of people or animals.
- High velocity fluid spray can cause objects to break, propelling particles at high speeds.

0° Nozzle - Red: This nozzle delivers a pinpoint stream of pressurized water and is extremely powerful. It covers only a small area of cleaning. This nozzle should only be directed at surfaces that can withstand high pressure such as metal or concrete. Do not use this nozzle to clean wood.

15° Nozzle - Yellow: This nozzle delivers a powerful 15 degree spray pattern for intense cleaning of small areas. This nozzle should only be used on areas and materials that can withstand high pressure.

25° Nozzle - Green: This nozzle delivers a 25 degree spray pattern for intense cleaning of larger areas. This nozzle should only be used on areas that can withstand pressure from this nozzle.

40° Nozzle - White: This nozzle delivers a 40 degree spray pattern and a less powerful stream of water. This nozzle can cover a wide area and should be used for most general cleaning jobs.

Chemical Nozzle - Black: This nozzle is used to apply special chemicals and cleaning solutions. This nozzle produces the weakest pressure stream of the five nozzles.

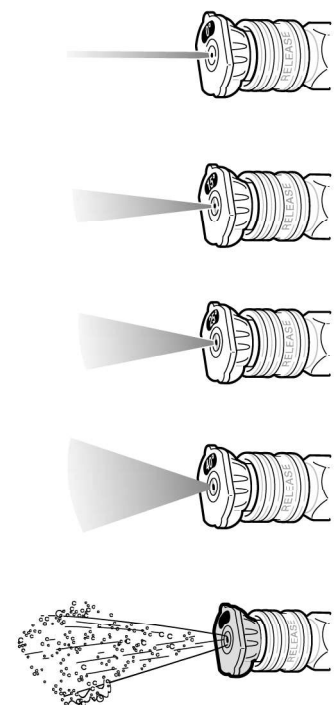

12. Maintenance

To ensure efficient operation and longer life of your pressure washer a routine maintenance schedule should be prepared and followed. If the equipment is used in unusual conditions such as high-temperature or dusty conditions more frequent maintenance checks will be required.

WARNING

Before performing any maintenance be aware that the equipment should be completely shutdown, depressurized and allowed to cool down. This will ensure that no injuries can be sustained by moving parts, water pressure or hot surfaces.

Engine contains flammable fuel do not smoke near or work near naked flames while maintaining this equipment. Please note: All repairs should be carried out by Dealer approved engineers. All replacement parts should be supplied or recommended by the Dealer. Any unapproved repairs or modifications will invalidate the warranty.

1. Engine:

Check the engine regularly, replace oil, clean spark plugs and maintain parts as required.

2. Pump Oil:

Change the pump oil regularly. Change the pump oil after the first 50 hours of work and successively every 200 hours. In either case ensure that the oil is changed at least once a year. Check with your nearest Dealer for advice on the best Pump Oil to use with this equipment if you are unsure.

NOTICE

Avoid prolonged or repeated skin contact with used motor oil.

Used motor oil has been shown to cause skin cancer in certain laboratory animals. Thoroughly wash exposed areas with soap and water.



KEEP OUT OF REACH OF CHILDREN. DON'T POLLUTE. CONSERVE RESOURCES. RETURN USED OIL TO COLLECTION CENTERS.

3. Nozzle Tips:

If the nozzle becomes clogged with dirt and debris excessive pressure can build up. If the nozzle becomes partially clogged or restricted the pump pressure will fluctuate and can become harmful and dangerous.

Clean the nozzle immediately and follow these instructions:

1. Shut-off the engine and turn off / disconnect the water supply.
2. Pull the trigger on the gun to relieve any water pressure.
3. Disconnect the lance from the gun.
4. Remove the nozzle from the lance - remove any obstructions with the nozzle cleaning tool and back flush with clean water.
5. Direct the water supply into the spray wand end to back flush loosened particles for 30 seconds.
6. Reassemble the nozzle onto the lance.
7. Reconnect the lance to the gun and turn on the water supply.
8. Start the washer pump and place the lance into the high pressure setting to test.

Nozzle Cleaning Pin

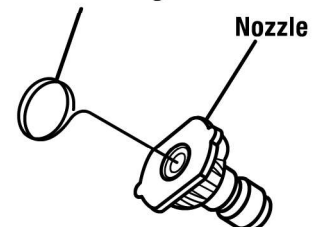

12. Maintenance (Continued)

4. Cleaning The Water Filter:

The water filter should be checked regularly and cleaned if necessary:

1. Turn the Fixing Nut of the water filter "Anticlockwise" and take out the strainer inside the clear bowl.
2. Clean the strainer and put back into the clear bowl, Re-install the filter and tighten the fixing nut.

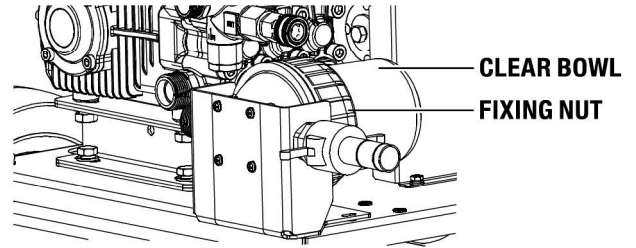

5. High Pressure Hose:

Replace the high pressure hose when the hose have any of the below circumstance:

1. Cover damaged.
2. Burst.
3. Bubbles/blisters.
4. Kinked/collapsed.

WARNING



The high pressure stream of water can cut through skin and its underlying tissues, leading to serious injury and possible amputation.

- Never repair high pressure hose. Replace it.
- Replacement hose rating MUST exceed maximum pressure rating of the unit.

6. Cleaning the Fuel Tank Filter:

The fuel tank filter should be removed and cleaned after every 150 hours of running or every 3 months using an environmentally friendly water-based de-greasing agent. Refit when clean.

7. Maintenance Schedule

Item	Task Description	Each Use	1st Month (20Hrs)	Frequency Each Season (50Hrs)	Every 6 Months (100Hrs)	Every YEAY (300Hrs)
Engine Oil	Oil Level Check	•				
	Replace		•		•	
Reduction Gear Oil (If applicable)	Oil Level Check	•				
	Replace		•		•	
Air Cleaner/filter	Check	•				
	Clean			•X	•X	
	Replace					•
Deposit Cup	Clean				•	
Spark Plug	Clean,Adjust				•	
	Replace					•
Spark Eliminator	Clean				•	
Idling	Check,Adjust					•
Valve Clearance	Check,Adjust					•
Fuel Tank & Filter	Clean					•
Fuel Supply Line	Check	Check with your Dealer for advice if any problem are detected				

Key:

* = Only for inside ventilating double core carburetors

** = Only for paper core cleaners

x = Repeat task more often than scheduled if equipment is used in dusty working environments

Δ = Maintenance to be carried out by Dealer approved technician

13. Storage

1. After General / Regular Use

1. Drain all water from the high pressure hose, coil it and hang on the cradle on the petrol washer frame. If chemicals were used ensure the pump and chemical hose are thoroughly cleaned out.
2. Drain all the water from the gun and lance by holding the gun in a vertical position with the nozzle end pointing down and squeeze the trigger. Store in the gun/hose holder.

2. Preparation for Winter and Long-term Storage

Note: It is recommended that you follow these steps to protect the internal seals of the pump when storing the equipment for more than 30 days and or when, freezing temperatures are expected.

1. Obtain a funnel, 200ml of antifreeze and approximately 1M of garden hose with a male hose connector attached to one end.
2. Disconnect the spark plug wire.
3. Connect the hose to water inlet on the pump.
4. Pour the antifreeze into the hose via the funnel.
5. Pull the engine starter cord slowly several times until antifreeze comes out of the high pressure water hose connection on the pump.
6. Remove the short hose from the water inlet on the pump.
7. Reconnect the spark plug wire.

3. Service After Storage

Before reusing the equipment after storage, you should carry out the following to keep the equipment in good condition.

Storage Time	Service Tank
Within one month	No service required
One - two months	Drain out the existing fuel out of the fuel tank and fresh fuel
Two months - one year	Drain out the existing fuel out of the fuel tank and fresh fuel Drain the fuel out of carburetor Empty the deposit cup
Over a year	Drain out the existing fuel out of the fuel tank and fresh fuel Drain the fuel out of carburetor Empty the deposit cup Close the FUEL VALVE and wait engine to stop

Key:

* = Unscrew the drain plug and drain out the fuel in the carburetor

** = Turn engine switch to the off position, disconnect the deposit cup and empty contents safely

Note: Do not dump oil vessels or discarded engine oil onto the ground. Take all discarded engine oil in a closed container to your nearest recycling station.

14. Troubleshooting

PROBLEM	PROBABLE CAUSE	SOLUTION
Engine shuts down when running.	<ol style="list-style-type: none"> 1. Out of fuel. 2. Low Engine Oil 	<ol style="list-style-type: none"> 1. Fill fuel tank. 2. Add oil.
Engine will not start; or starts and runs rough.	<ol style="list-style-type: none"> 1. Rocker switch set to "OFF" position. 2. Fuel valve is in "OFF" position. 3. Dirty air cleaner 4. Out of fuel. 5. Stale fuel. 6. Spark plug wire not connected to spark plug. 7. Bad spark plug. 8. Water in fuel. 9. Flooded. 10. Excessively rich fuel/air mixture. 11. Intake valve stuck open or closed. 12. Engine has lost compression. 13. Low engine oil. 14. Wrong Fuel. 15. Engine is too hot 16. Chock is in wrong position 17. Pressure Builds up after 2 pulls on recoil starter or after initial use. 	<ol style="list-style-type: none"> 1. Set switch to "ON" position. 2. Turn fuel valve to "ON" position. 3. Clean or replace air cleaner 4. Fill fuel tank. 5. Drain fuel tank and carburetor; fill with fresh fuel. 6. Connect wire to spark plug. 7. Replace spark plug. 8. Drain fuel tank and carburetor; fill with fresh fuel. 9. Wait 5 minutes and re-crank engine. 10. Contact authorized service facility. 11. Contact authorized service facility. 12. Contact authorized service facility. 13. Add oil. 14. Use recommended fuel. 15. Allow engine to cool 16. Change chock position 17. Squeeze gun trigger to relieve pressure.
Engine "Hunts" or falters.	<ol style="list-style-type: none"> 1. Carburetor is running too rich or too lean. 	<ol style="list-style-type: none"> 1. Contact authorized service facility.
Engine lacks power.	<ol style="list-style-type: none"> 1. Cylinder pressure is low. 2. Dirty air cleaner 	<ol style="list-style-type: none"> 1. Contact authorized service facility. 2. Replace air filter.
No pressure or Low pressure.	<ol style="list-style-type: none"> 1. Spray wand not set to high pressure. 2. Lower water supply. 3. Hose fitting leaks during high pressure. 4. Nozzle obstructed. 5. Water filter screen obstructed. 6. Defective thermal relief valve. 7. Air in hose. 8. Choke lever in choke position. 9. Throttle control lever is hot in fast position. 10. High pressure too long. 	<ol style="list-style-type: none"> 1. See "Using Spray Wand" section. 2. Water supply must be 5 GPM @ 20 psi. 3. Tighten hose fitting. Use thread sealant tape if necessary. 5. Remove and clean filter. 6. Call Customer Service: 7. Stop engine and water source. Disconnect water source from pump inlet and turn water source to ON to remove all air from hose. When steady stream of water is present, turn water source to OFF. Re-connect water source to pump inlet and turn on water source. Squeeze trigger to remove remaining air. 8. Move choke to NO CHOKE position. 9. Move throttle control lever from fast position. 10. Use High pressure hose under 100 ft (30M).

14. Troubleshooting (Continued)

PROBLEM	PROBABLE CAUSE	SOLUTION
Pump will not draw Chemicals	<ol style="list-style-type: none"> 1.Spray wand not set to low pressure.. 2.Chemical filter clogged. 3.Chemical screen not in chemical. 4.Chemical solution too thick. 5.Pressure hose too long 6.Chemical build-up in chemical injector. 	<ol style="list-style-type: none"> 1. See "Using Spray Wand" section. 2. Clean Filter. 3. Ensure end of chemical hose is fully submerged into chemicals. 4. Dilute chemical. Chemical solutions should have same consistency as water. 5. Lengthen water supply hose instead of pressure hose. 6. Have parts cleaned or replaced by authorized dealer.
No or low pressure (after period of normal use).	<ol style="list-style-type: none"> 1. Worn seal or packing. 2. Worn or obstructed valves. 3. Worn unloader piston. 4. Worn E-Z start valve. 	Have parts cleaned or replaced by authorized dealer.
Water leaking at spray gun/spray wand connection.	<ol style="list-style-type: none"> 1. Worn or broken O-ring. 2. Loose hose connection. 	<ol style="list-style-type: none"> 1. Check and replace O-ring. 2. Tighten hose connection.
Water leaking at pump.	<ol style="list-style-type: none"> 1. Loose connections. 2. Piston packings worn. 3. Worn or broken O-rings. 4. Pump head or tubes damaged from freezing. 	<ol style="list-style-type: none"> 1. Check and replace O-ring 2. Tighten hose connection. 1. Tighten connections. 2. Have parts cleaned or replaced by authorized dealer. 3. Have parts cleaned or replaced by authorized dealer. 4. Have parts cleaned or replaced by authorized dealer.
Oil leaking at pump	<ol style="list-style-type: none"> 1. Oil seals worn. 2. Loose drain plug. 3. Worn drain plug O-ring. 4. Worn fill plug O-ring. 5. Pump overfilled. 6. Incorrect oil used. 7. Vent plug clogged. 	<ol style="list-style-type: none"> 1. Have parts cleaned or replaced by authorized dealer. 2. Tighten drain plug. 3. Inspect and replace O-ring. 4. Inspect and replace O-ring. 5. Check for correct amount. 6. Drain and refill with correct type and amount of oil. 7. Clean vent plug. Use air hose to free it of blockage. If problem persists, replace vent plug.
Pump pulsates	Nozzle obstructed.	See "Using Spray Wand" section.

15. Pressure Washer Exploded View & Parts List

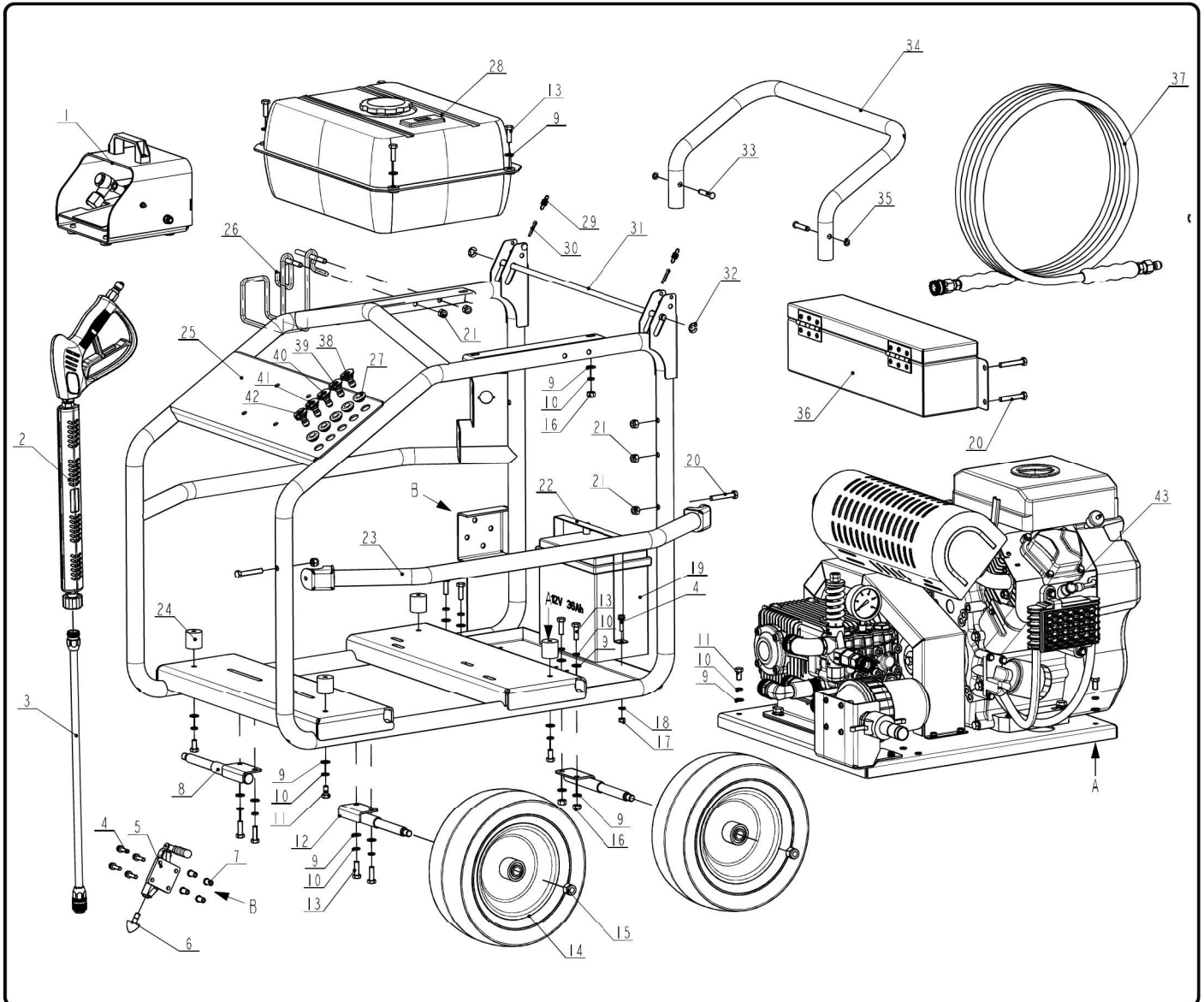

NO. DESCRIPTION

- 1 Foot Actuated Penal (Drain Jetting Only)
- 2 High Pressure Gun
- 3 High Pressure Wand
- 4 Bolt M6x25
- 5 Brake Body
- 6 Brake Head
- 7 Nut
- 8 Wheel Axle (Right Side)
- 9 Plain Washer
- 10 Spring Washer
- 11 Bolt M8x16
- 12 Wheel Axle (Left Side)
- 13 Bolt M8x25
- 14 13" Pneumatic Wheel

NO. DESCRIPTION

- 15 Nut M12
- 16 Nut M8
- 17 Nut M6
- 18 Plain Washer
- 19 Battery
- 20 Bolt M8x50
- 21 Nut M8
- 22 Battery Fixing Bar
- 23 Side Handle
- 24 Anti-vebration Feet M8x30
- 26 Hook (Right)
- 27 Nozzle Grommet
- 28 Fuel Tank

NO. DESCRIPTION

- 29 Spring
- 30 Open End Pin
- 31 Push Barb
- 32 Open Washer
- 33 Axle
- 34 Handle
- 35 Open Washer
- 36 Tool Box
- 37 High Pressure Hose
- 38 0 Degree Nozzle
- 39 15 Degree Nozzle
- 40 25 Degree Nozzle
- 41 40 Degree Nozzle
- 42 Black Soap Nozzle
- 43 Pump, Engine and Base Plate Assy

16. Pump Exploded View & Parts List

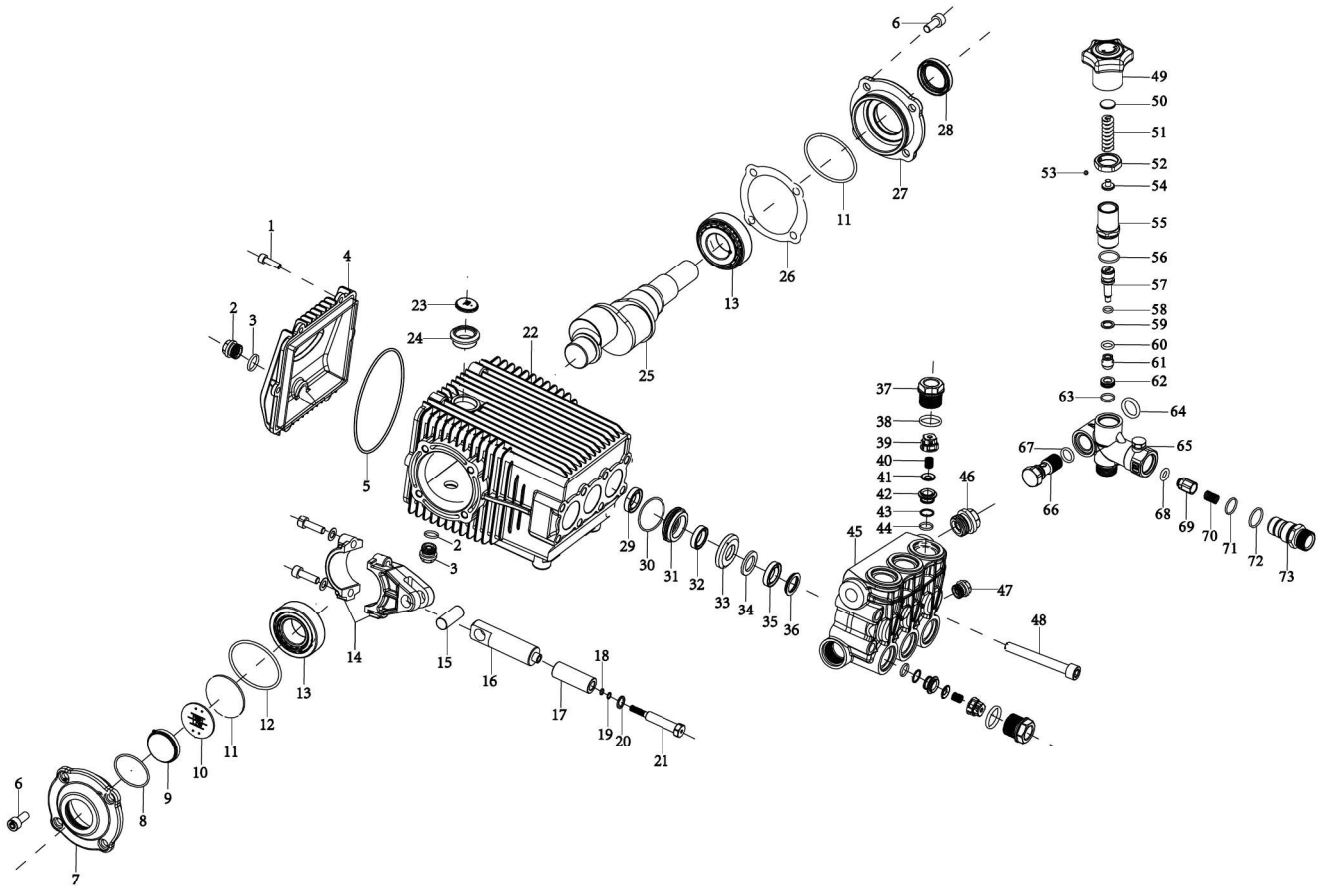

NO.	DESCRIPTION
1	Bolt
2	Drain Plug
3	O-ring
4	Crankcase Cover
5	O-ring
6	Bolt
7	Bearing Cover
8	O-ring
9	Oil Gauge
10	Oil Level Indicate Plate
11	Clamp Ring
12	O-ring
13	Bearing
14	Connecting Rod
15	Pin
16	Plunger Guide
17	Ceramic Tube
18	Backup Ring
19	O-ring
20	Washer
21	Fixing Bolt
22	Crankcase
23	Oil Cap Cover
24	Oil Cap
25	Crankshaft

NO.	DESCRIPTION
26	Washer
27	Bearing Cover
28	Oil Seal
29	Plunger Oil Seal
30	O-ring
31	Seal Retainer
32	Low Pressure Seal
33	Compaction Ring
34	Compaction Flake
35	High Pressure Seal
36	Supporting Seat
37	Valve Plug
38	O-Ring
39	Valve Cage
40	Spring
41	Valve Disc
42	Valve Seat
43	Backup Ring
44	O-ring
45	Manifold
46	Manifold Upper Plug
47	Manifold Lower Plug
48	Manifold Fixing Bolt
49	Adjusting Knob
50	Upper Seat

NO.	DESCRIPTION
51	Spring
52	Jam Nut
53	Set Screw
54	Spring Seat
55	Spring Housing
56	O-ring
57	Spindle
58	O-ring
59	Backup Ring
60	O-ring
61	Valve Bullet
62	Valve Seat
63	O-ring
64	Oring
65	Valve Housing
66	O-ring
67	Banjo Bolt
68	O-ring
69	Outlet Checking Valve
70	Spring
71	O-ring
72	O-ring
73	Outlet Fitting

17. Gearbox Exploded View & Parts List

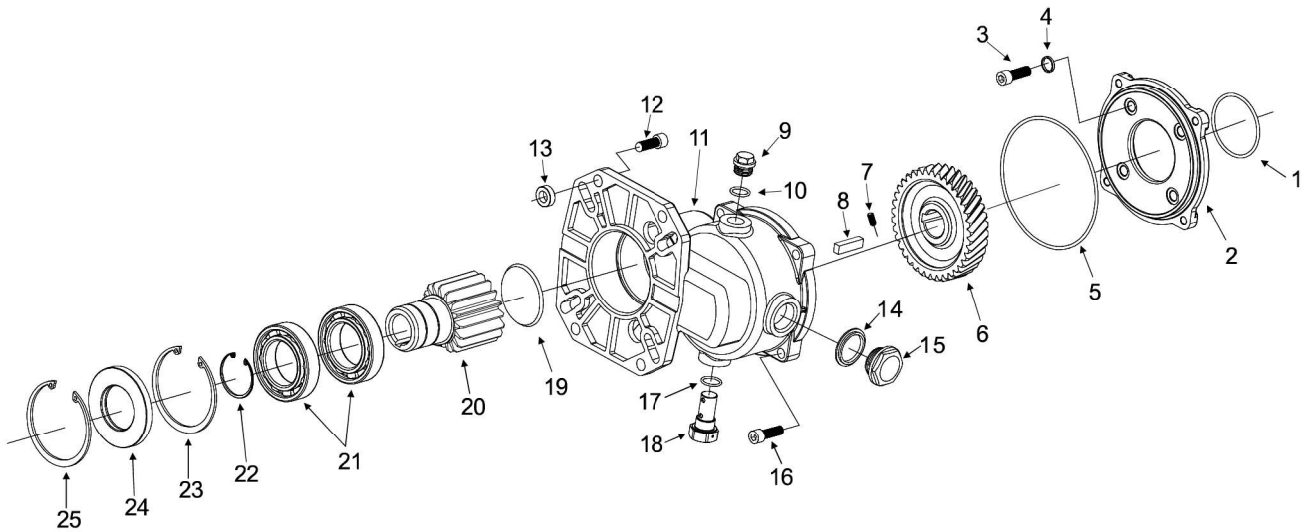

NO. DESCRIPTION

- 1 O-Ring
- 2 Mounting cover
- 3 Bolt
- 4 Washer
- 5 O-Ring
- 6 Pump gear
- 7 Set screw
- 8 Key

NO. DESCRIPTION

- 9 Oil drain plug
- 10 O-Ring
- 11 Case
- 12 Bolt
- 13 Washer
- 14 Gasket
- 15 Sight gauge
- 16 Bolt

NO. DESCRIPTION

- 17 O-Ring
- 18 Venting plug
- 19 Blocking flake
- 20 Engine gear
- 21 Bearing
- 22 Snap ring
- 23 Snap ring
- 24 Oil seal
- 25 Snap ring

IMPORTANT! SAFETY FIRST!

Before attempting to use this product(s) please read all of the safety precautions and operating instructions outlined in this manual to reduce the risk of damage to the products and personal injury.